

TYPE 1 & 2 WALL DIMENSIONS

NO. OF COURSES	TOTAL HEIGHT "H" + "E"	MAX. EFFECTIVE HEIGHT "H"	MIN. BASE WIDTH "W"	
			TYPE 1	TYPE 2
2*	720	520(A)	720	350(B)
3	1090	740	1000	720
4	1460	1110	1370	1000
5	1830	1480	1740	1000
6	2200	1850	2110	1090
7	2570	2220	2480	1370
8	2940	2590	2850	1740
9	3310	2960	3220	2110
10	3680	3330	3590	2480
11	4050	3700	3960	2850
12	4420	4070	4330	3220
13	4790	4440	4700	3590
14	5160	4790	5070	3960
15	5530	5180	5440	4330
16	5900	5550	5810	4700
17	6270	5920	6180	5070
18	6640	6290	6550	5440

TYPE 1 = STRUCTURAL RETAINING WALL - STRUCTURE TO BE ON BOUNDARY OR MIN. 1.0m AWAY.

TYPE 2 = NON STRUCTURAL RETAINING WALL - NO STRUCTURE OR OFFSET MIN. OF (H + W + D)

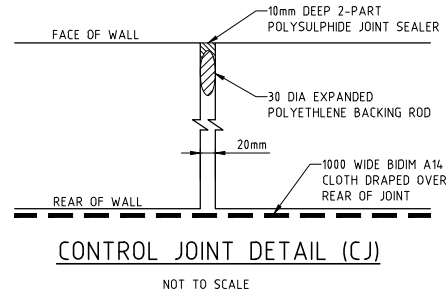
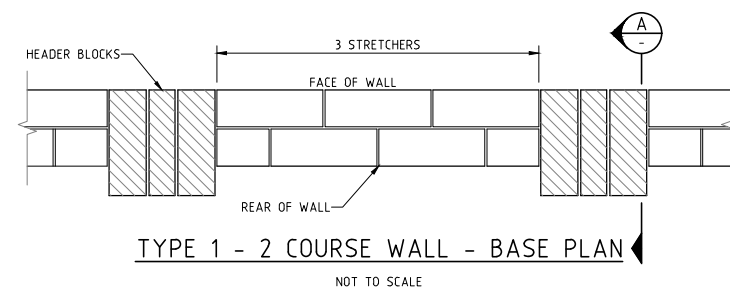
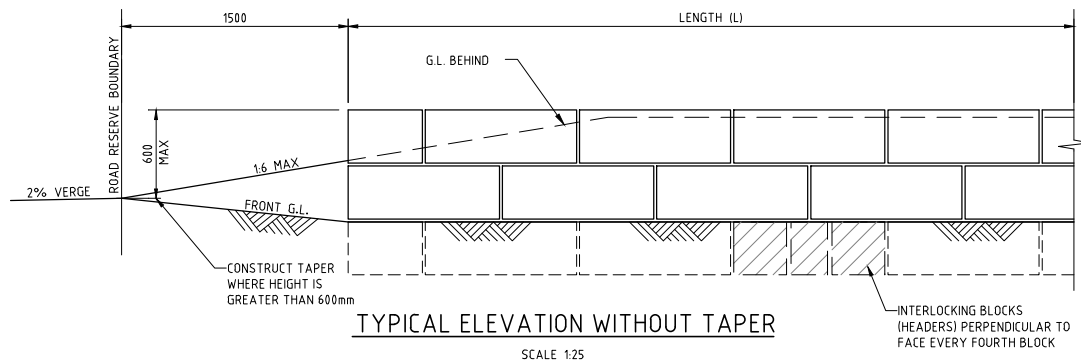
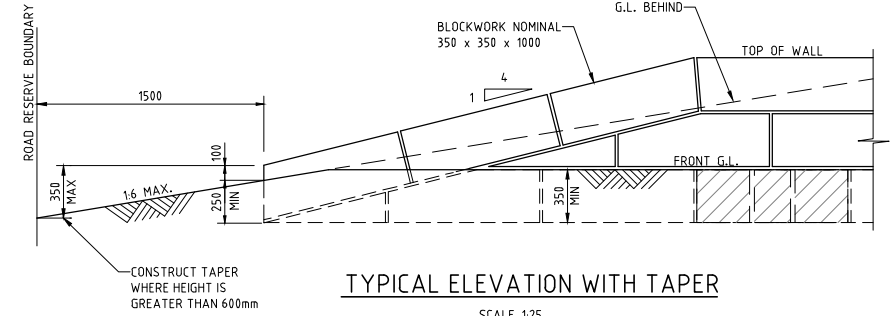

- NOTES:**
- DESIGN**
THE WALL IS DESIGNED FOR STABLE SAND (CLASS 'A1' OR SLIGHTLY REACTIVE CONDITIONS (CLASS 'S')) TO AS2870, WITH FREE DRAINING GRANULAR BACKFILL AND MIN 600mm SAND PAD BELOW BASE. FOUNDATION TO BE FREE OF DELETERIOUS MATERIAL. MAXIMUM WATER TABLE TO BE BELOW BOTTOM OF WALL, IF OTHER CONDITIONS ARE ENCOUNTERED ON SITE, CONTACT THE ENGINEER PRIOR TO CONSTRUCTION.
 - WALL TYPE 1**
DEAD LOADS (INCLUDING BUILDINGS) PLACED BEHIND WALLS SHOULD BE NO CLOSER THAN 1.0m UNLESS LOCATED DIRECTLY ON TOP. MAXIMUM SURCHARGE LOAD TO BE 40kN/m WHICH ALLOWS FOR A TWO STOREY BUILDING.
 - WALL TYPE 2**
ENSURE DEAD LOAD (INCLUDING BUILDINGS) PLACED BEHIND WALLS IS NO CLOSER TO THE WALL THAN A DISTANCE EQUAL TO H+E+W. MAXIMUM SURCHARGE LOAD TO BE 2.5kPa WHICH INCLUDES LIGHT VEHICLE SURCHARGE.
 - COMPACTION**
COMPACT THE SOIL AT THE BASE TO 100kPa ALLOWABLE BEARING CAPACITY OR 95% MODIFIED MAXIMUM DRY DENSITY FOR A MINIMUM DEPTH OF 600mm BELOW BASE OF WALL.
 - LIMESTONE**
LIMESTONE TO BE RECONSTITUTED BLOCKS (MINIMUM DENSITY OF 1800kg/m AND MINIMUM COMPRESSIVE STRENGTH OF 2MPa). FULL BLOCKS TO BE 350x350x1000, HALF BLOCKS TO BE 165x350x1000. ALTERNATIVELY 240x350x100 BLOCKS CAN BE USED TO MEET MINIMUM WALL DIMENSIONS. BLOCKS ARE TO BE LAID IN STRETCHER BOND. LIMESTONE TO BE FREE FROM SOFT POCKETS AND GENERALLY FREE FROM SURFACE DEFECTS.
 - INTERLOCKING BLOCKS**
FOR WALL TYPE 1 AND/OR WHEN FENCE POSTS ARE TO BE CORE DRILLED INTO WALL, PROVIDE INTERLOCKING BLOCKS (HEADERS) AT 4m CENTRES. LOCATE AT 3c AND EACH COURSE THEREAFTER WITH INTERLOCKING SETS TO BE STAGGERED WITH ADJACENT COURSE.
 - JOINTS**
ALL JOINTS ARE TO BE MORTARED WITH 1:1.6 CEMENT:LIME:SAND. MORTAR TO BE M3 CLASSIFICATION, EXCEPT PROJECTS LOCATED WITHIN 1km OF THE OCEAN ARE TO BE M4 CLASSIFICATION. CEMENTS OTHER THAN TYPE GP PORTLAND CEMENT & 100% WHITE PORTLAND CEMENT SHALL NOT BE USED. RUBBLE NOT TO BE USED TO FILL VOIDS. ALL JOINTS ARE TO BE 20mm.
 - BACKFILL**
DO NOT BACKFILL WALL UNTIL AT LEAST 7 DAYS AFTER COMPLETION. BACKFILL TO BE COMPACTED TO A 95% MODIFIED MAXIMUM DRY DENSITY OR EQUIVALENT.
 - CONTROL JOINTS**
PROVIDE 20mm CONTROL JOINTS WHERE SHOWN ON DESIGN DRAWINGS OR OTHERWISE AT MAX 40m CENTRES IN STRAIGHT LENGTHS OF WALLS. WHERE WALL CHANGES DIRECTION, CONTROL JOINTS ARE LOCATED 1m FROM THE CORNER FOR WALLS TO 4c IN HEIGHT, 1.5m FOR WALLS BETWEEN 5c AND 8c IN HEIGHT, AND 2m FROM THE CORNER FOR WALLS 9c AND ABOVE. FILL JOINTS WITH 30DIA EXPANDED POLYETHYLENE BACKING ROD, COVERED WITH A 10mm 2-PART POLYSULPHIDE JOINT SEALER.
 - LOCATION**
RETAINING WALLS TO BE LOCATED WHOLLY WITHIN THE RETAINED LOT. FOOTING BLOCKS SHALL BE LOCATED TO A MAXIMUM TOLERANCE OF 25mm WITHIN THE RETAINED LOT, AND 0mm OUTSIDE THE CADASTRAL BOUNDARY OF THE RETAINED LOT.
 - COMPLETION**
THE CONTRACTOR SHALL PROVIDE WRITTEN CERTIFICATION OF PRACTICAL COMPLETION THAT THE WALL CONSTRUCTION AND BACKFILLING HAS BEEN CARRIED OUT IN ACCORDANCE WITH THIS DRAWING & SPECIFICATIONS. ALL WALLS FACING ROAD RESERVES, P.A.W.'S & P.O.S.'S ARE TO BE TREATED WITH A NON SACRIFICIAL ANTI-GRAFFITI COATING.

***NOTE:**
(A) - ALL 2 COURSE WALLS REQUIRE ONLY 200mm MINIMUM EMBEDMENT (U.N.O.)
(B) - FOR TYPE 2 - 2 COURSE WALLS HEADER BLOCKS ARE NOT REQUIRED

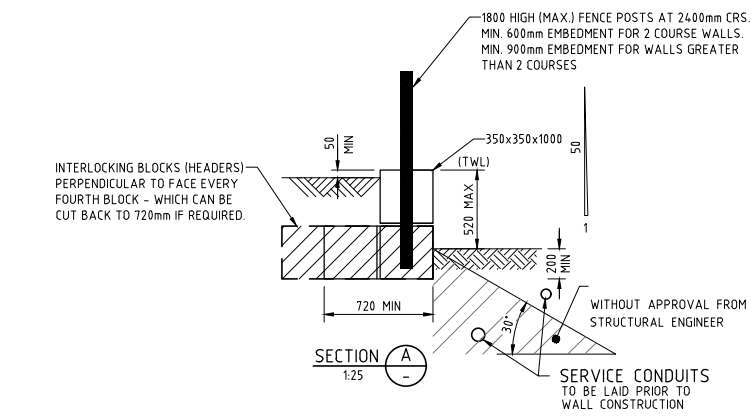

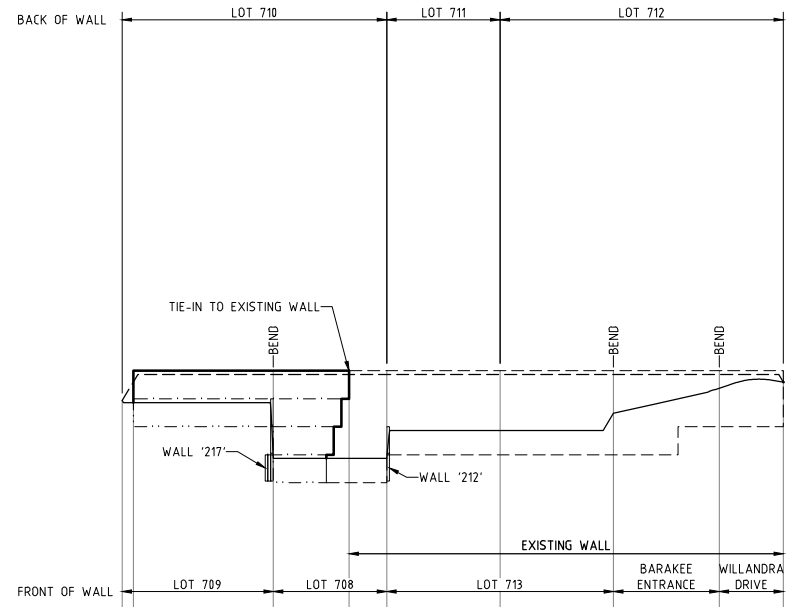

DATUM RL.25.0		LOT 710		LOT 711		LOT 712		LOT 709		LOT 708		LOT 713	
TOP OF WALL	28.00	28.00	28.42	28.42	28.42	28.42	28.42	28.42	28.42	28.42	28.42	28.42	28.42
BACK OF WALL	28.03	28.28	28.37	28.37	28.37	28.37	28.37	28.37	28.37	28.37	28.37	28.37	28.37
FRONT OF WALL	28.03	28.00	27.26	27.26	27.26	27.26	27.26	27.26	27.26	27.26	27.26	27.26	27.26
CHAINAGE	0.00	1.50	20.00	30.00	35.00	50.00	65.00	76.99	81.49				
WALL TYPE	TYPE 1												

RETAINING WALL '211'
HORIZ. - 1:500
VERT. - 1:50

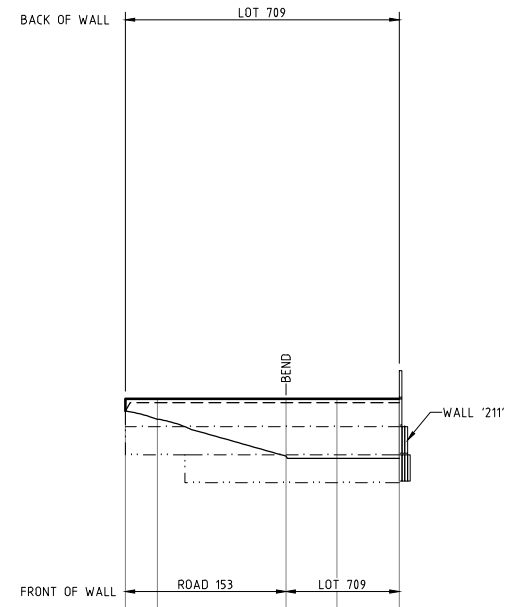

DATUM RL.25.0		LOT 709	
TOP OF WALL	27.89	28.05	28.05
BACK OF WALL	27.89	28.00	28.00
FRONT OF WALL	27.89	27.78	27.29
CHAINAGE	0.00	4.25	21.24
WALL TYPE	TYPE 1		

RETAINING WALL '211'
HORIZ. - 1:500
VERT. - 1:50

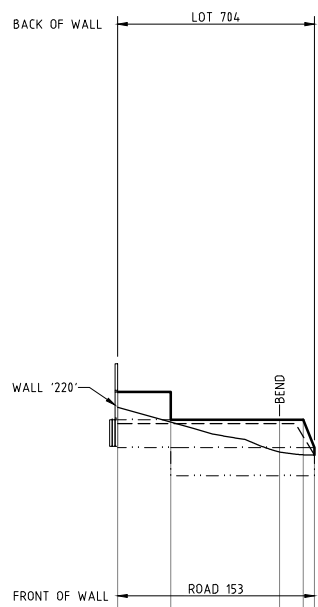

DATUM RL.23.0		LOT 704	
TOP OF WALL	26.20	26.20	25.83
BACK OF WALL	25.78	25.78	25.83
FRONT OF WALL	26.00	25.80	25.40
CHAINAGE	0.00	7.00	21.41
WALL TYPE	TYPE 2	TYPE 1	

RETAINING WALL '222'
HORIZ. - 1:500
VERT. - 1:50

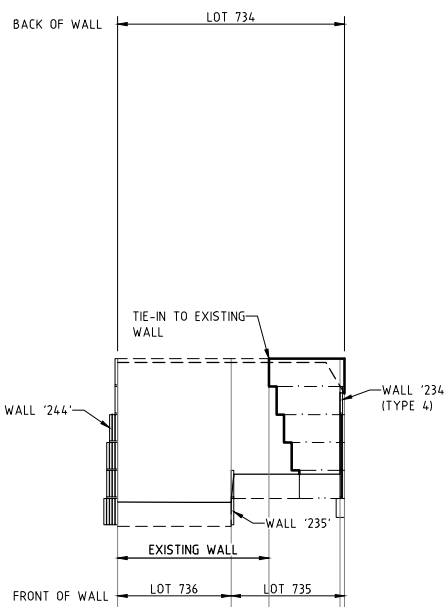

DATUM RL.23.0		LOT 734		LOT 736		LOT 735	
TOP OF WALL	26.64	26.64	26.64	26.64	26.64	26.64	26.18
BACK OF WALL	26.59	26.59	26.59	26.59	26.59	26.59	26.18
FRONT OF WALL	24.74	24.74	25.11	25.11	25.11	25.11	24.88
CHAINAGE	0.00	15.00	20.00	29.40	30.00		
WALL TYPE	TYPE 1						

RETAINING WALL '233'
HORIZ. - 1:500
VERT. - 1:50

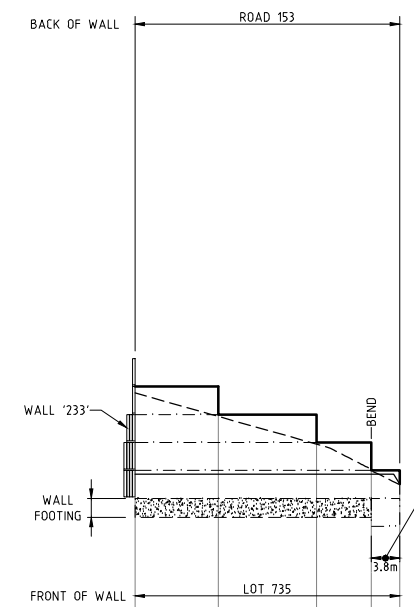

DATUM RL.23.0		ROAD 153		LOT 735	
TOP OF WALL	26.27	26.27	25.90	25.90	25.53
BACK OF WALL	26.18	26.87	25.51	25.51	25.53
FRONT OF WALL	25.11	25.11	25.15	25.15	25.18
CHAINAGE	0.00	11.00	24.00	31.25	35.01
WALL TYPE	TYPE 4				TYPE 1

RETAINING WALL '234'
HORIZ. - 1:500
VERT. - 1:50

THIS SECTION TO BE 500x350x350 BLOCKS (FINISH TO MATCH TYPE 4 WALL BLOCKS) WITH NO PERPENDICULAR BASE BLOCKS

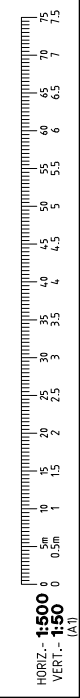

Copyright	This document shall remain the property of Development Engineering Consultants Pty. Ltd. The document may only be used for the purpose for which it was commissioned & in accordance with the terms of engagement for the commission. Unauthorised use of this document in any way is prohibited.		
No.	DATE	BY	REVISION
A	15/06/20	PMS	INITIAL ISSUE
			RDG

CLIENT:
DEPARTMENT OF HOUSING

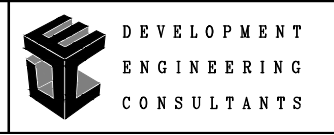







SUITE 3, 123A COLIN ST.
WEST PERTH, 6005
WESTERN AUSTRALIA
Ph: (08) 9481 1900
Fax: (08) 9481 1700

PROJECT:
**LOT 1 YANCHEP BEACH ROAD
YANCHEP
JINDOWIE - STAGE 19B**
W.A.P.C. No. - 157404 (MODIFIED) & 158554

DRAWING:
**EARTHWORKS
RETAINING WALL LONGSECTIONS**

SCALE H-1:500, V-1:50	DRAWN PMS	CHECK RDG	REV No. A
DATE JUNE '20	DESIGNED PMS	APPROVED RDG	
PROJECT NUMBER YANAUS52 E03		DRAWING NUMBER YANAUS52 E03	

LEGEND

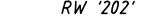
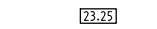
-  PROPOSED RETAINING WALLS
-  EXISTING RETAINING WALL
-  FUTURE RETAINING WALLS
-  COLORBOND FENCING - COLOUR = "GREYRIDGE"
-  OPEN FENCING
-  FINISHED GROUND LEVELS
-  RETAINING WALL REFERENCE
-  LOT LEVEL

NOTES:

1. RETAINING WALLS OVER 1.0m SHALL HAVE A 1.2m HIGH RINGLOCK AND STAR IRON PICKET FENCE INSTALLED ON TOP.
2. TO BE READ IN CONJUNCTION WITH RETAINING WALL LONGSECTION, STANDARD RETAINING WALL DETAILS AND EARTHWORKS DRAWINGS.
3. ADD EXTRA BLOCKS AS INDICATED ON ELECTRICAL DRAWING

WALL SETOUT INFORMATION

WALL No.	START VERGE RL	FRONT OF WALL RL	BACK OF WALL RL	TOP OF WALL RL	END VERGE RL	LENGTH	No. OF COURSES
218	26.84	26.89	27.26	27.31	-	28.50	2
219	26.42	26.52	26.89	26.94	-	28.50	2
220	26.00	25.78	26.52	26.57	-	10.00	3
231	-	26.59	27.33	27.38	26.66	28.50	3
243	-	27.33	27.70	27.75	27.14	28.50	2

REFER STANDARD WALL DETAILS FOR TYPICAL SECTION

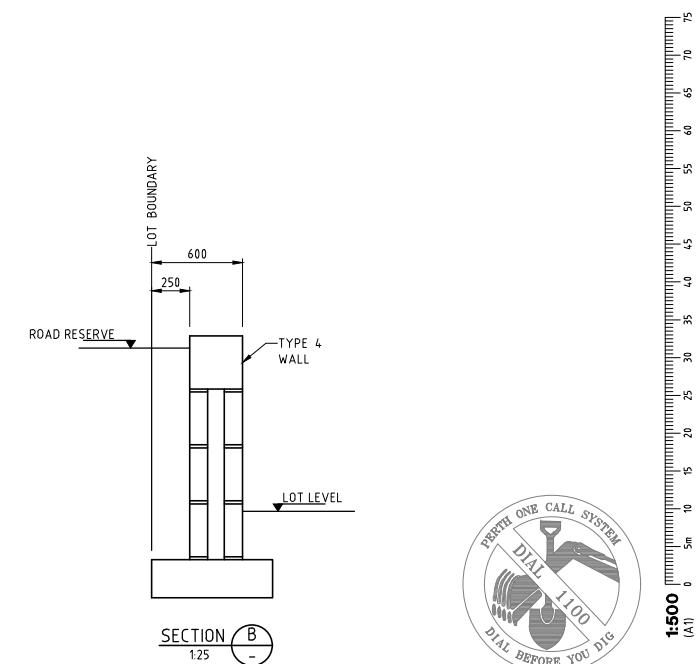
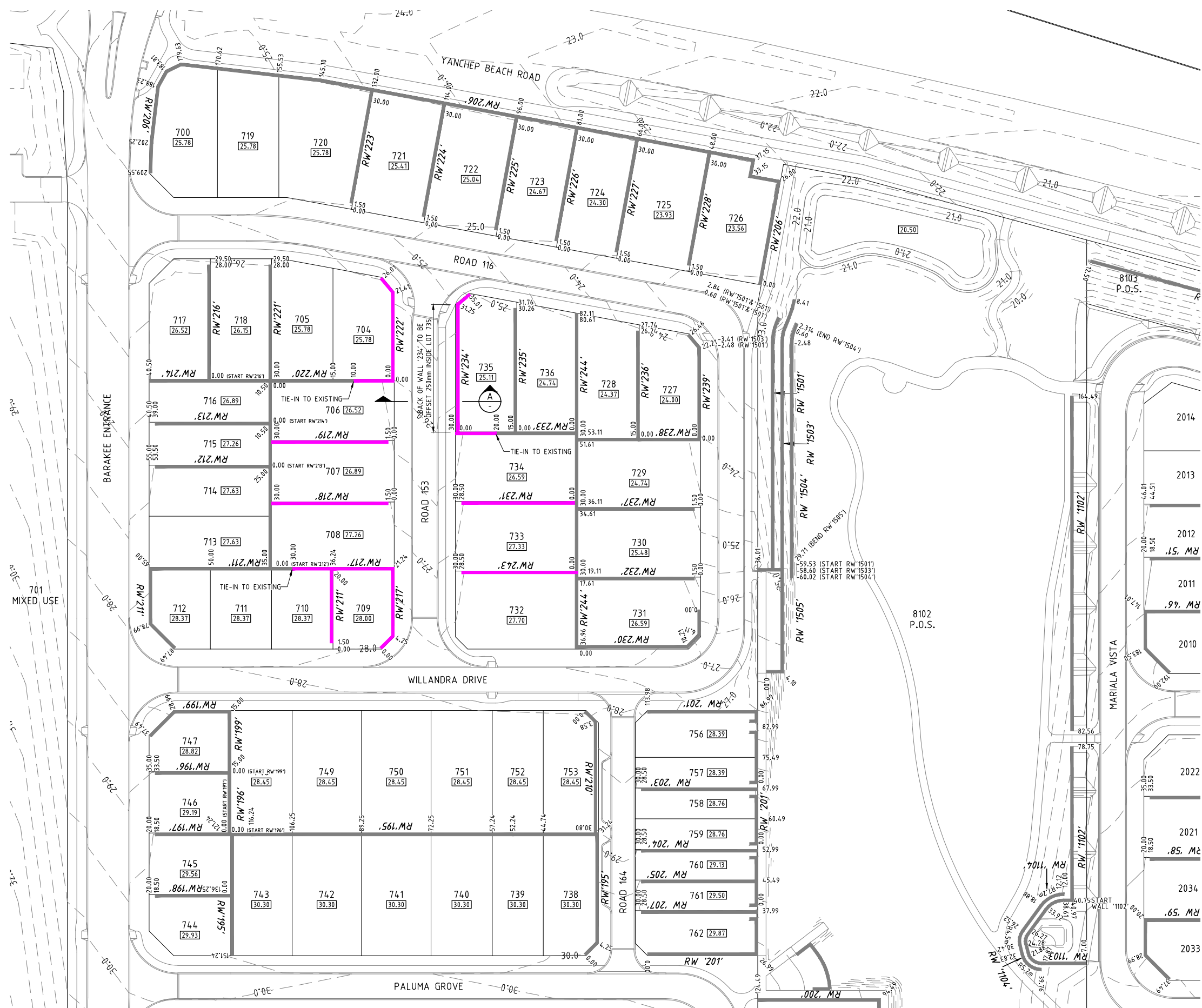

No.	DATE	BY	REVISION
A	15/06/20	PMS	INITIAL ISSUE

CLIENT:
DEPARTMENT OF HOUSING

DEVELOPMENT ENGINEERING CONSULTANTS
SUITE 3, 123A COLIN ST.
WEST PERTH, 6005
WESTERN AUSTRALIA
Ph: (08) 9481 1900
Fax: (08) 9481 1700

PROJECT:
**LOT 1 YANCHEP BEACH ROAD
YANCHEP
JINDOWIE - STAGE 19B**
W.A.P.C. No. - 157404 (MODIFIED) & 158554

DRAWING:
**EARTHWORKS
RETAINING WALL LAYOUT PLAN**

SCALE	DRAWN	CHECK	REV No.
1:500	PMS	RDG	A
DATE	DESIGNED	APPROVED	
JUNE '20	PMS	RDG	

PROJECT NUMBER: **YANAUS52 E02**
DRAWING NUMBER: **YANAUS52 E02**